

PLAN SECTION

SCALE 1:10

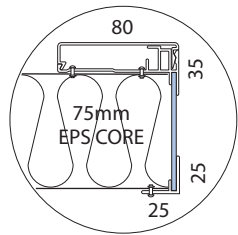

ALTERNATIVE
P/C ALUM.
ARCHITRAVE

DETAIL

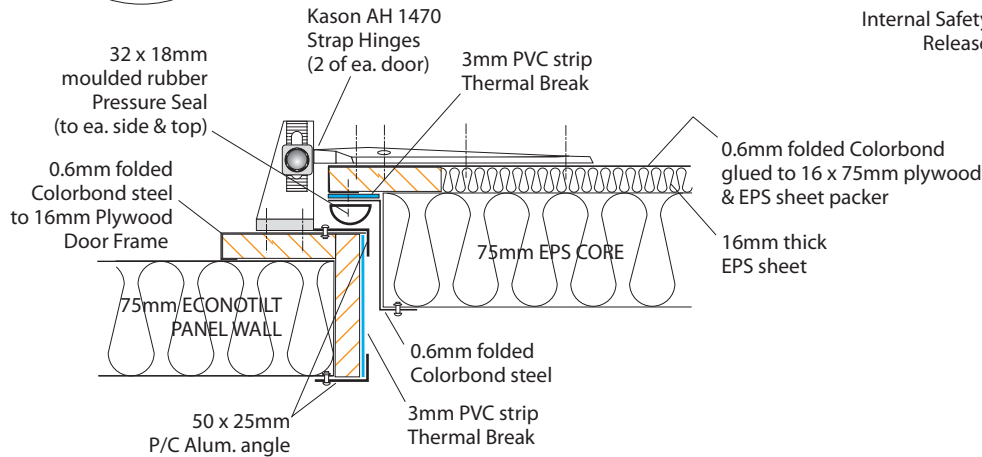

CHILLED CHAMBER

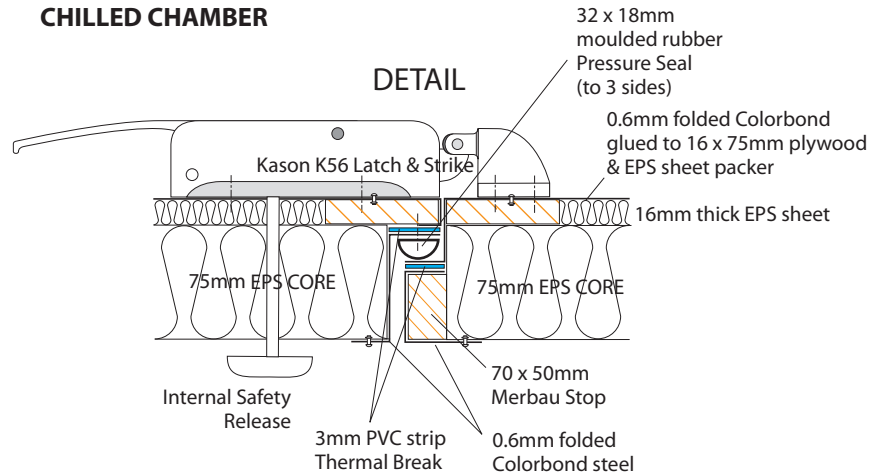

CHILLED CHAMBER

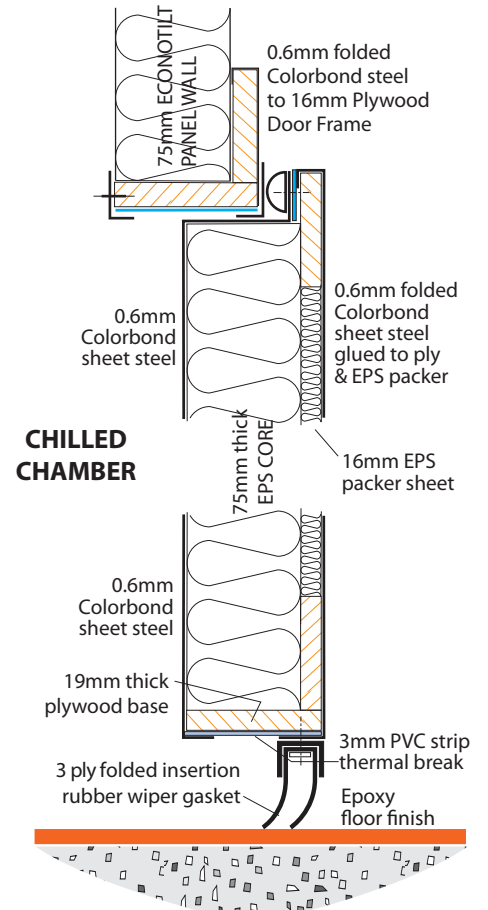

CROSS SECTION OF EACH DOOR

SCALE 1:5

THIS DRAWING IS THE PROPERTY OF AUSTRAL INSULATION AND MAY NOT BE REPRODUCED IN WHOLE OR IN PART WITHOUT THEIR PRIOR WRITTEN CONSENT. ALL COPYRIGHT RESERVED.



HINGED OFFICE DOORS

Sizes available: H x W x Door thickness
 2000 x 1600 x 38 Dble. door
 2100 x 1500 x 75 Dble. door
 3000 x 2500 x 38 Dble. door

HINGED CHILLER DOORS

Sizes available: H x W x Wall thickness
 2000 x 1800 x 75 Dble. door
 2100 x 1600 x 38 Dble. door

Bi-part doors are all made to order. Any configuration of sizes can be made to suit the application.

DOOR DETAILS
EPS Core
HINGED BI-PART DOOR - Chiller

Drawn	SDH
Date	28.03.08
Rev.	08.09.08
Checked	
Drg. N ^o .	E6